

PRODUCT DATASHEET

Confidex Ironside™



The most durable tag for challenging industrial asset management applications

ELECTRICAL SPECIFICATION

Device type

Class 1 Generation 2 passive UHF RFID transponder

Air interface protocol

EPCGlobal Class1 Gen2 ISO 18000-6C

Operational frequency

Global 860-960MHz

IC type

Impinj Monza4 QT™

Impinj Monza4 E™ (upon special request)

Memory configuration

With Monza4 QT: EPC 128 bit; User 512 bit; TID 96 bit

With Monza4 E: EPC 496 bit; User 128 bit; TID 96 bit

EPC memory content

Unique number encoded as a default

Read range (2W ERP)*

EU on metal up to 9 m / 30 ft

US on metal up to 7 m / 23 ft

JPN on metal up to 8m / 26 ft

off metal read ranges 3-4 m / 10-13 ft

Applicable surface materials*

Ideal application on metal, works on any material

* Read ranges are theoretical values that are calculated for non-reflective environment, in where antennas with optimum directivity are used with maximum allowed operating power according to ETSI EN 302 208 (2W ERP). EU = 865 - 868 MHz, US = 902 - 928 MHz, JPN = 952-956 MHz. Different surface materials may have an effect on performance.

RADIATION PATTERNS

On metal

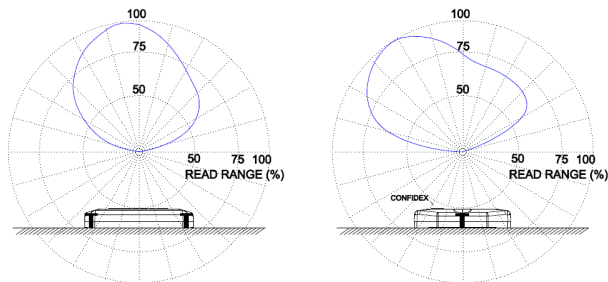

MECHANICAL SPECIFICATION

Tag materials

High quality engineering plastics. Surface thermoplastic elastomer.

Standard compliancy

SAE AS5678.

Weight

22 g

Delivery format

Single

Amount in box

500pcs

Dimensions

51,5 x 47,5 x 10 mm / 2.03 x 1.87 x 0.39 in

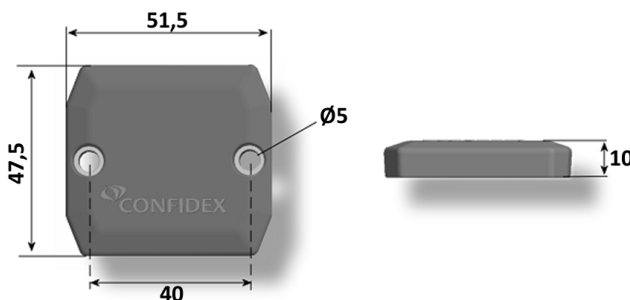

ENVIRONMENTAL RESISTANCE

Operating temperature

-40°C to +85°C / -40°F to +185°F

Ambient temperature

-55°C (for 3h) to +105°C / -67°F (for 3h) to +221°F

Peak temperature

+125°C / +257°F 1h duration

IP classification

IP68

Weather ability

Excellent, including UV-resistance and sea water

Pressure resistance

170kPa for 10min

Vibration resistance

- JESD22-B103B, service condition 2; vibration that is

aligned with tag thickness (z-axis)

- RTCA DO-160 Rev E 8.5

Operational shock

RTCA DO-160 Rev E 7.2

Chemical resistance

No physical or performance changes in:

- 168 hour Motor oil exposure

- 168 hour Salt water (salinity 10%) exposure

- 168 hour Sulfuric acid (10%, pH 2) exposure

- 24 hour NaOH (10%, pH 13) exposure

Generally good against: Methanol (moderate concentrations), ethanol (moderate concentrations), glycerine, ethylene glycol, consistent grease, most acids, bases and tensides such as sulfuric acid 96%, nitric acid 10%, NaOH 50%, soap solution 30%. Testing recommended for hydrocarbons and some of the carboxylic acids. Acetone should be avoided.

Expected lifetime

Years in normal operating conditions

Values in the table are the best recommendations; resistance against environmental conditions depends on the combination of all influencing factors, exposure duration and chemical concentrations. Thus, product's final suitability for certain environmental conditions is recommended to be tested. Contact Confidex for more specific information.

PERSONALIZATION OPTIONS

Pre-encoding

- Customer specific encoding of EPC or user memory. Locking permanently or with password.

Customized laser engraving

- Customer specific layout including logo, text, numbers.

INSTALLATION INSTRUCTIONS

Confidex Ironside™ can be attached with several fixing methods:

1. 3M 300LSE high performance acrylic adhesive (not included by default)

When background adhesive is ordered the tag is delivered with adhesive attached. When mounting the tag with its adhesive background, clean and dry the surface for obtaining the maximum bond strength. Ideal application temperature is from +21°C to +38°C (+70°F to +100°F), bond strength can be improved with firm application pressure and moderate heating from +38°C to +54°C (+100°F to +130°F). Installation at temperatures below 10°C (50°F) is not recommended.

2. Other adhesive fixings
 - Silicone sealants

Silicone sealants like Dow Corning AS 7096 provide very high bond strength and resistance against mechanical stress. When tag is attached with sealant adhesive, insert a layer of sealant under the tag and press the tag on the surface. Increase the bond by adding extra sealant from the tag holes. Inset maximum 3mm layer of adhesive under the tag. Please refer to silicone sealant supplier for exact fixing instructions.

3. Mechanical fixing
 - Screws (size M4)
 - Pop rivets (size 4mm)

Mechanical fixing is recommended to be used in every application that includes risk for high mechanical stress or low temperature during tag fixing. During fixing make sure there is no air gap left in between the metal surface and tag.

4. Additional fixing tools
 - Welding bracket



When the application is too demanding for adhesives, but the metal surface can not be punched for screw or rivet fixing, welding the tag with special bracket is an option for attachment. Welding bracket is made of stainless steel and delivered ready attached to tag with pop rivets.

Procedure: Welding bracket will be spot welded on the metal surface. Dimples in the design will ease the welding. Tag is usually riveted to the bracket in advance so the bracket is ready to be used. Bracket design allows attachment on both flat and curved surfaces.

For the optimal performance please locate the tag on metal like shown in picture on the right. Ideally the tag is placed on large even metal surface with direct metal contact underneath the whole tag.



ORDER INFORMATION

Product number: 3000319
Product name: Confidex Ironside™ Global M4QT

Following product is available upon special request:
Product number: 3000616
Product name: Confidex Ironside™ Global M4E

For other versions, additional information and technical support contact Confidex Ltd.

DISCLAIMER
 THE MATERIALS, PRODUCTS AND SERVICES ARE SOLD SUBJECT TO ITS STANDARD CONDITIONS OF SALE, WHICH ARE INCLUDED IN THE APPLICABLE DISTRIBUTOR OR OTHER SALES AGREEMENT. ALTHOUGH ANY INFORMATION, RECOMMENDATIONS, OR ADVICE CONTAINED HEREIN IS GIVEN IN GOOD FAITH, CONFIDEX MAKES NO WARRANTY OR GUARANTEE, EXPRESS OR IMPLIED, (i) THAT THE RESULTS DESCRIBED HEREIN WILL BE OBTAINED UNDER END-USE CONDITIONS, OR (ii) AS TO THE EFFECTIVENESS OR SAFETY OF ANY DESIGN INCORPORATING ITS PRODUCTS, MATERIALS, SERVICES, RECOMMENDATIONS OR ADVICE. EXCEPT AS PROVIDED IN CONFIDEX STANDARD CONDITIONS OF SALE, CONFIDEX AND ITS REPRESENTATIVES SHALL IN NO EVENT BE RESPONSIBLE FOR ANY LOSS RESULTING FROM ANY USE OF ITS MATERIALS, PRODUCTS OR SERVICES DESCRIBED HEREIN.

Each user bears full responsibility for making its own determination as to the suitability of Confidex products, materials, services, recommendations, or advice for its own particular use. Each user must identify and perform all tests and analyses necessary to assure that its finished systems incorporating Confidex products, materials, or services will be safe and suitable for use under end-use conditions. Nothing in this or any other document, nor any oral recommendation or advice, shall be deemed to alter, vary, supersede, or waive any provision of this Disclaimer, unless any such modification is specifically agreed to in a writing signed by Confidex.

